

UDC 669.296:621.785.062

V. Voyevodin¹, DSc, Prof.,
V. Trush², Ph.D.,
V. Fedirko², DSc, Prof.,
A. Luk'yanenko², Ph.D.,
P. Stoev¹, DSc, Prof.,
M. Tikhonovsky¹, Ph.D.

¹Institute of Solid State Physics Materials and Technologies, National Science Center "Kharkov Institute of Physics and Technology" of the National Academy of Sciences of Ukraine, 1 Academic Str., Kharkov, Ukraine, 61108

²Karpenko Physico-Mechanical institute of the National Academy of Sciences of Ukraine, 5 Naukova Str., Lviv, Ukraine, 79060;
e-mail: trushvasyl@gmail.com

INCREASING LONG-TERM STRENGTH OF Zr-1%Nb ALLOY BY DIFFUSIVE HARDENING OF NEAR-SURFACE LAYER

V.M. Восводін, В.С. Труш, В.М. Федірко, О.Г. Лук'яненко, П.І. Стоєв, М.А. Тихоновський. Підвищення тривалої міцності сплаву Zr-1%Nb дифузійним зміцненням приповерхневого шару. Цирконієві сплави широко застосовуються як конструкційний матеріал у атомній промисловості для виготовлення оболонок тепловиділяючих елементів – (ТВЕЛів). Експлуатаційна надійність цих конструкцій – важливий елемент надійності усього паливного циклу, враховуючи, що конструкції працюють за підвищених температур. Тому розроблення режимів фінішної хіміко-термічної обробки ТВЕЛів зі сплаву Zr-1%Nb є важливою і актуальною задачею в галузі матеріалознавства цирконію та його сплавів. Метою роботи є встановити вплив обробки у різних контрольованих газових середовищах (вакуум, кисневмісне, азотовмісне) на тривалу міцність сплаву Zr-1%Nb за температури 380 °C на повітрі. Дослідним матеріалом є зразки-кільця шириною 3 мм (зовнішній діаметр 9,2 мм) з V-подібним концентратором глибиною 0,5 мм, які вирізані з трубок ТВЕЛів зі сплаву Zr-1%Nb українського виробництва. Для випробувань зразків-кілець сплаву Zr-1%Nb на тривалу міцність при температурі $T=380$ °C на повітрі використовували багатопозиційну установку, розроблену у ФМІ НАН України. Для кріплення зразків-кілець на установці на випробування на тривалу міцність було розроблено та виготовлено спеціальні захвати. Хіміко-термічну обробку здійснювали у розрідженому ($P=1 \cdot 10^{-4}$ мм. рт. ст.) газовому середовищі (вакуумі), а також у розрідженому кисне- та азотовмісному газових середовищах за температури $T=580 \dots 650$ °C та експозиції $\tau=3 \dots 10$ год. Експериментально досліджено вплив окиснення, азотування та обробки у вакуумі на товщину, мікротвердість поверхневих шарів цирконієвих зразків-кілець, а також опірність сповільненому руйнуванню за тривалого статичного навантаження. Експериментально встановлено, що обробка цирконієвих зразків-кілець сплаву Zr-1%Nb у кисневмісному та азотовмісному газових середовищах відносно вакуумного відпалу підвищує руйнівні напруження за тривалого статичного навантаження при температурі $T=380$ °C на повітрі. Показано відмінності поверхні зламу приповерхневого шару зразків-кілець сплаву Zr-1%Nb в залежності від режиму обробки.

Ключові слова: цирконій, хіміко-термічна обробка, кисень, азот, приповерхневий шар, тривала міцність

V. Voyevodin, V. Trush, V. Fedirko, A. Luk'yanenko, P. Stoev, M. Tikhonovsky. **Increasing long-term strength of Zr-1%Nb alloy by diffusive hardening of near-surface layer.** Zirconium alloys are widely used as structural material in nuclear industry for fabrication of nuclear fuel claddings (NFC). The operational reliability of these structures is an important element of reliability of the entire fuel cycle, given that the structures operate at elevated temperatures. The development of finishing thermochemical treatment modes of Zr-1%Nb alloy NFC is an important and actual task in the field of materials science of zirconium and its alloys. The aim of the work is to determine the influence of thermal treatment in various controlled gas media (vacuum, oxygen-containing, nitrogen-containing) on the long-term strength of the Zr-1%Nb alloy samples at 380 °C in air. The experimental material is 3 mm ring-samples with a 0.5 mm depth V-shaped concentrator, which are cut from NFC tubes of the Zr-1%Nb alloy of Ukrainian production. In order to test long-term strength of Zr-1%Nb alloy ring-samples at $T=380$ °C in air a multipositional assembly was used. The assembly was designed and manufactured in the Karpenko Physico-Mechanical institute of the National Academy of Sciences of Ukraine. Special grips were developed and produced for mounting ring-samples on a long-term strength test. Thermochemical treatment was conducted in a rarefied ($P=1 \cdot 10^{-4}$ mm Hg) gas medium (vacuum), as well as in rarefied oxygen- and nitrogen-containing gas media at temperature $T=580 \dots 650$ °C and at the exposure $\tau=3 \dots 10$ h. The influence of oxidation, nitration and vacuum treatment on thickness and microhardness of surface layers of zirconium ring-samples, as well as resistance to delayed failure under a static long-term load are studied experimentally. Also it has been experimentally established that the treatment of zirconium ring-samples of the Zr-1%Nb alloy in oxygen-containing and nitrogen-containing gas media with respect to vacuum annealing raises the destructive stresses with a prolonged static load at a temperature of 380 °C in air. The differences in fracture surface of near-surface layer of the Zr-1%Nb alloy ring-samples, depending on the processing mode, are shown in the paper.

Keywords: zirconium, thermochemical treatment, oxygen, nitrogen, near-surface layer, long-term strength

DOI: 10.15276/opu.2.55.2018.06

© 2018 The Authors. This is an open access article under the CC BY license (<http://creativecommons.org/licenses/by/4.0/>).

Introduction. Due to a combination of unique physical-mechanical and nuclear properties, zirconium and its alloys are widely applied in nuclear engineering. This makes them almost a non-alternative construction material for operation in the core of thermal neutron reactors [1, 2].

Among the topical problems in the field of metal science of zirconium, the following can be distinguished: ensuring high resource characteristics of zirconium products by developing new or optimizing existing regimes treatments. Having regard to the fact that physical-mechanical properties of zirconium are sensitive to the content of interstitial element (oxygen, nitrogen, carbon), the thermochemical treatment is an effective option, namely the purposeful diffuse saturation of the near-surface layer by the interstitial element, in particular by oxygen and nitrogen.

Analysis of recent publications and problem statement. According to the literary data, the performance properties of zirconium are significantly affected by an interstitial element – oxygen, which reacts easily and takes part in all processes occurring in the material under various conditions: thermal, mechanical, radiation. However, the data on the regularities of the above-mentioned influence remain limited and contradictory [3 – 7]. It should also be noted that the presence of nitrogen in zirconium alloys also affects their properties [8, 9].

The solubility of the interstitial elements (oxygen, nitrogen) in zirconium is of particular practical importance. According to the state diagram, the maximum solubility of oxygen in α -zirconium is 28 at. % and for nitrogen – 22 at. % (Fig. 1) [10, 11]. The significant solubility of oxygen and nitrogen in zirconium makes the alloys of the “Zr-O” and “Zr-N” system promising from the point of view of practical use of doping by these interstitial elements as a method of controlling the structure and properties of the zirconium alloy.

Dissolution of oxygen and nitrogen in the matrix of zirconium significantly affects the ductility and strength: with increasing content of the elements of the embodiment, plasticity is reduced, and strength is increased [7].

Oxygen also affects the fatigue properties of zirconium alloys. For example, scientists studied the fatigue life at $T=25\text{ }^{\circ}\text{C}$ and at $T=350\text{ }^{\circ}\text{C}$ (Fig. 2) of zirconium samples that were cut from thin tubes with different oxygen content (E110opt alloy with an oxygen content of 0.007...0.008 mass % and E1100 with an oxygen content of 0.003...0.004 mass %) [12].

Positive effect of oxygen on fatigue life both at room temperature and at elevated $T=350\text{ }^{\circ}\text{C}$ has been shown in the article [13]. The positive effect of oxygen on the fatigue life of zirconium is also fixed by other researchers. The authors associate probable cause of such a positive effect of oxygen on the fatigue life of zirconium with formation of an interstitial solid solution in a metal matrix. The oxygen content affects the nature of zirconium alloys fracture.

The fracture surface of zirconium alloys with different oxygen content (140...1740 ppm) has been analyzed in the article [13]. The authors note that the fracture surface of an alloy with high oxygen content contains a large number of fatigue grooves, which confirms the high energy intensity of destruc-

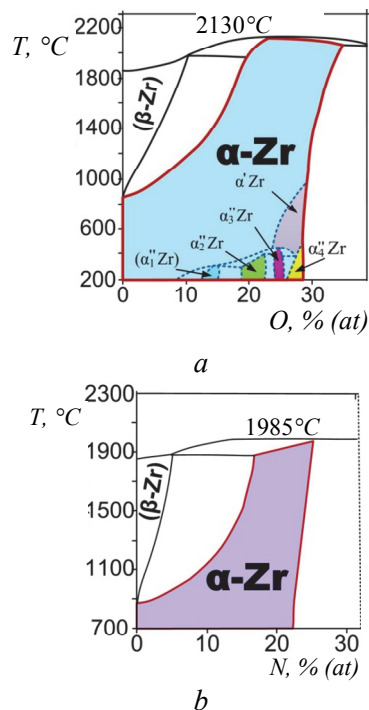

Fig. 1. Fragment of state diagrams: “Zr – O” (a) [10], “Zr – N” (b) [11]

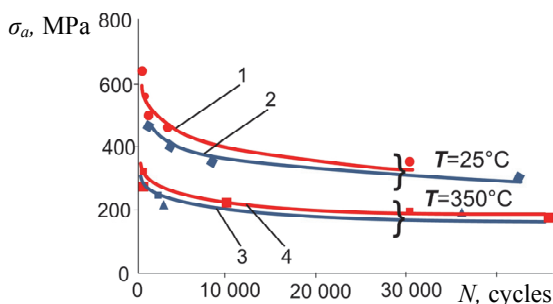

Fig. 2. The fatigue curves of samples of E110opt zirconium alloys (oxygen content 0.007...0.008 mass %) (2, 4) and E110 (oxygen content 0.003...0.004 mass %) (2, 4) at $T=25\text{ }^{\circ}\text{C}$ (1, 3) and at $T=350\text{ }^{\circ}\text{C}$ (2, 4) [12]

tion. It was noted in [6] that an increase in oxygen content leads to a decrease in the twinning process and in the initiation of nucleation of micro pores at later stages of uniform plastic deformation.

Thermochemical treatment is one of the effective methods for controlling structure and characteristics of near-surface metal layers, and as a result significantly affects the functional properties of the metal. Therefore, it is advisable to broaden the notion of the influence of the near-surface layer enriched by interstitial elements on the properties of NFC tubes of Zr-1%Nb alloy. In particular, it is advisable to establish the effect of treatment in controlled gas media on the long-term strength of the Zr-1%Nb alloy at temperature of $T=380\text{ }^{\circ}\text{C}$, which has been investigated in this work.

Purpose. The aim of the work is to determine the influence of thermal treatment in various controlled gas media (vacuum, oxygen-containing, nitrogen-containing) on the long-term strength of the Zr-1%Nb alloy samples at $380\text{ }^{\circ}\text{C}$ in air.

Methodology of experiment. The object of research was the selection of tubes made of Zr-1%Nb zirconium alloy of Ukrainian production [14].

Tests of long-term strength in air at temperature of $T=380\text{ }^{\circ}\text{C}$ based on 100 hours were carried out on 3 mm wide ring-samples with a V-shaped concentrator of 0.5 mm depth cut symmetrically from both sides of the ring sample (Fig. 3).

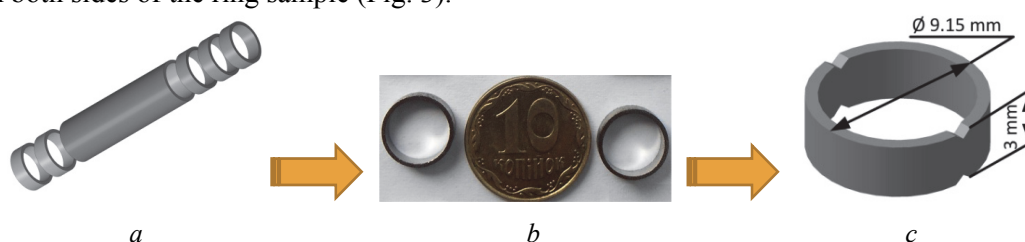

Fig. 3. The principal scheme for making ring-samples for testing for a long-term strength: cut of the ring-samples from the NFC tube (a), grinding and polishing ends (b), application of concentrators (c)

The multistation equipment (Fig. 4), developed in PhMI NAS of Ukraine [15], was used for long-term strength tests. The advantage of this system is its multistation device, which makes it possible to provide identical test conditions for a large number of samples and will accelerate the duration of the research.

The base part of the equipment (Fig. 4) is a massive plate 1 on four supports 2 with cushion pad. A loading mechanism is mounted on the plate for testing samples for long-term strength. The electric pit furnace 4 of the SShOL1.1.6/12 type is strengthened below on the two screws 3. The test samples 5 are located radially around the central support rod 6. The lower stationary excitement 7 is pivotally connected to a support ring fixedly positioned under the rod 6.

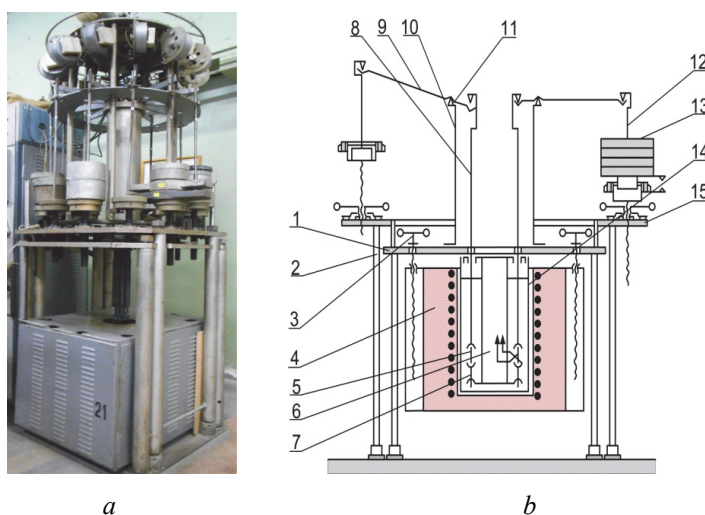

Fig. 4. The general view (a) and scheme (b) of the equipment for long-term strength tests (delayed failure under static long-term load): 1 – plate, 2 – support, 3 – screw, 4 – electric furnace, 5 – sample for tests, 6 – central support rod, 7 – immobile delight, 8 – active thrust, 9 – double-armed levers, 10 – support, 11 – prism, 12 – suspension, 13 – weights, 14 – protective glass, 15 – support table

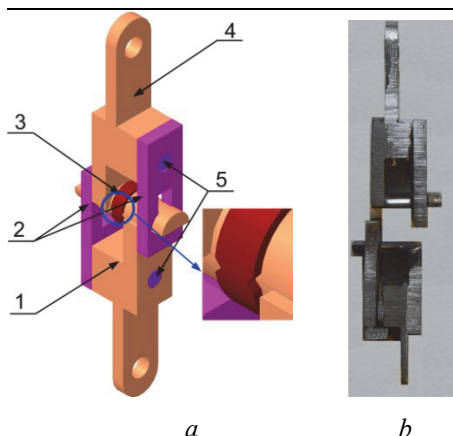

Fig. 5. The three-dimensional model (a) and the general view (b) of the gripper for fixing the ring-samples on delayed failure under static long-term load: 1 – lower base, 2 – side bar, 3 – ring-samples, 4 – upper base, 5 – pin

In the plant six ring-samples can be placed simultaneously, each of which has an individual load mechanism. The top position of the active rod 8 makes it possible to conveniently place the load device consisting of two-arm levers 9 (shoulder ratio 1:5) and supports 10 with prisms 11. Active pull rod is suspended on the prisms from the short end of each lever, and suspension 12 with weights 13 – from the long one. The supporting prisms 11 of the levers are arranged in a circle on the flanges of the cylindrical support 10. The fastening of the samples in the grippers is carried out with the help of pins. Samples are closed with a removable cup 14, designed to equalize the temperature in the working area of the chamber in conditions of conducting studies under higher temperatures.

The equipment has a remote control panel, on the front panel of which there are control elements of the installation, monitoring systems and signaling of breakage of samples. The results of tests for delayed failure were given in the coordinates “destructive stress σ – the logarithm of time to failure”.

In order to fasten the ring-samples to the installation, special grippers have been designed and made (Fig. 5).

The surface gas-saturated layer was formed by diffuse saturation from a controlled oxygen- and nitrogen-containing gas medium under various conditions (Table 1). Thermal treatment of the ring-samples was carried out on laboratory thermal equipment.

The following parameters were used to evaluate the effect of the thermochemical treatment regimes on the studied material: the surface hardness increase $\Delta H = (H_{\text{surf.}} - H_{\text{core}})$, where $H_{\text{surf.}}$ – hardness of the metal surface; H_{core} – the hardness of the metal core, and the depth of the strengthened layer – l , μm . The microhardness distribution over the cross section of the samples was determined on the PMT-3M instrument for loading 0.49H.

Table 1

The regimes of thermochemical treatment of Zr-1%Nb alloy ring-samples

№ treatment	Treatment regimes	Symbol
1	Initial state (vacuum annealing) $T=580\text{ }^{\circ}\text{C}$, $P=1 \cdot 10^{-4}\text{ mm Hg}$, $\tau=3\text{ hours}$	R1
	Treatment in an oxygen-containing medium	
2	$T=580\text{ }^{\circ}\text{C}$, $P=1 \cdot 10^{-2}\text{ mm Hg}$, $\tau=0.5\text{ hour}$ + $T=580\text{ }^{\circ}\text{C}$, $P=1 \cdot 10^{-4}\text{ mm Hg}$, $\tau=2.5\text{ hours}$	R2
	Treatment in a nitrogen-containing medium	
3	$T=650\text{ }^{\circ}\text{C}$, $P=1 \cdot 10^{-5}\text{ mm Hg}$, $\tau=1\text{ hour}$. + $T=580\text{ }^{\circ}\text{C}$, $P=760\text{ mm Hg}$, N_2 , $\tau=10\text{ hours}$	R3

Results of the research. According to the results of measuring the microhardness after vacuum treatment, oxidation and nitriding, the surface layer is not hardened and has small dimensions $l=9\text{...}14\text{ }\mu\text{m}$ (Table 2). Apparently, this is due to the low treatment temperature. However, it should be noted that oxidation and nitriding leads to an increase of hardness of the sample surface with respect to vacuum treatment. The existence of a strengthened surface layer after treatments is due to the gradient distribution of the elements of the interstitial elements (oxygen, nitrogen) in the near-surface layer [15].

Table 2

Characteristics of the near-surface layer of Zr-1%Nb zirconium alloy ring-samples after various regimes treatment

Regimes treatment	Microhardness HV _{0.49}		Increase in surface hardness ΔHV (HV ^{surf} – HV ^{core})	Depth of the hardened layer, <i>l</i> μm
	Surface HV ^{surf}	Core HV ^{core}		
R1	225±35	180±15	45	R1
R2	295±20	180±20	115	R2
R3	240±20	185±20	55	R3

It has been established that treatment in controlled gas media affects the long-term strength of ring-samples from Zr-1% Nb alloy at $T=380\text{ }^{\circ}\text{C}$ in air for $\tau=100$ hours (Fig. 6).

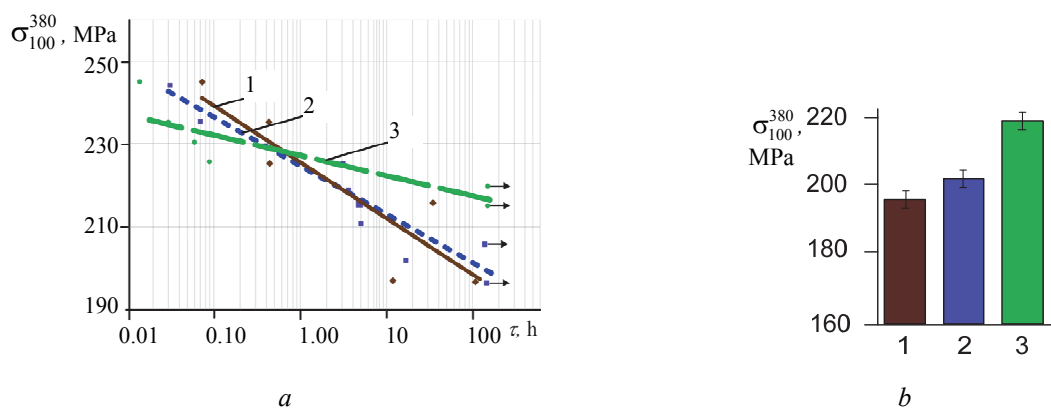

Fig. 6. Long-term strength of zirconium alloy Zr-1%Nb ring-samples in air at temperature $T=380\text{ }^{\circ}\text{C}$ after various treatment regimes: 1 – R1 regime; 2 – R2 regime; 3 – R3 regime: fatigue curve (a), failure stress on the basis of 100 h (b)

The failure stress of ring-samples at $T=380\text{ }^{\circ}\text{C}$ in air at a base of $\tau=100$ hours after treatment in R2 and R3 regimes in oxygen-containing and nitrogen-containing gas media, respectively, are larger than the failure stress of ring-samples after annealing in vacuum (Fig. 6). Especially this applies to treatment in a nitrogen-containing medium (R3 regime). This behavior of oxidized and nitrided ring-samples can probably be explained by the fact that as a result of thermochemical treatment the near-surface layer of the metal was enriched with the interstitial elements (oxygen, nitrogen). It was this modified layer that contributed to an increase in resistance to fracture. In order to further elucidate the reasons for this behavior, additional research will be carried out.

It is also necessary to note that the fracture of the studied Zr-1%Nb alloy ring-samples after the tests for the resistance to delayed failure under a static long-term load at $T=380\text{ }^{\circ}\text{C}$ in air for $\tau=100$ hours occurred in the zone of the V-shaped concentrator (Fig. 7).



Fig. 7. General view of ring-samples of Zr-1 %Nb alloy rings during long-term static strength tests: before the tests (a), after the tests (b)

According to the analysis of the fracture surface of rings-samples after loading at $T=380\text{ }^{\circ}\text{C}$ in air for $\tau=100$ hours, there are no significant differences in the mechanisms of destruction; all samples are destroyed mainly by a ductile mechanism (Fig. 8).

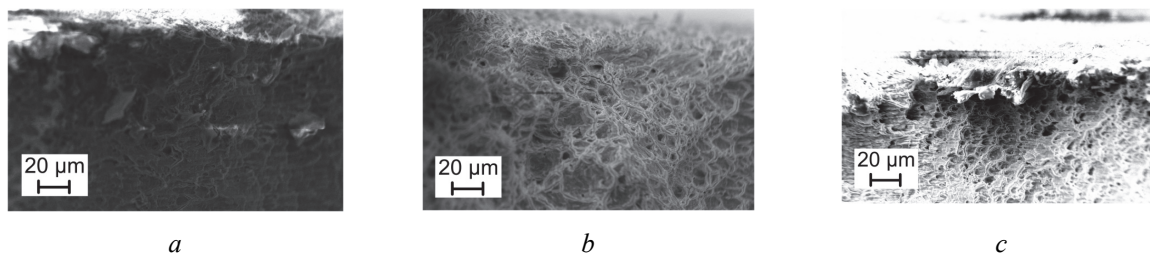

Fig. 8. The fracture surface of near-surface layer of the ring-sample after treatment at $T=380\text{ }^{\circ}\text{C}$ for 100 h after various treatment regimes: R1 regime (a); R2 regime (b); R3 regime (c)

The practical value of the obtained results is that the results of the research can be used in the development of new schemes for the finishing treatment of zirconium alloys in order to increase the durability in air for 100 hours at temperature of $T=380\text{ }^{\circ}\text{C}$.

Conclusions. The thermochemical treatment of ring-samples of Zr-1%Nb alloy cut from NFC tubes in various gas media (oxygen containing, nitrogen-containing) increases their long-term strength in air tests for 100 hours at temperature of $T=380\text{ }^{\circ}\text{C}$ in comparison with standard heat treatment in vacuum.

Література

1. Lemaignan C., Motta A.T. Zirconium Alloys in Nuclear Applications. *Materials Science and Technology*. 2006. P. 2–51. DOI: <https://doi.org/10.1002/9783527603978.mst0111>.
2. Nuclear corrosion science and engineering. Edited by Damien Feron. Woodhead Publishing Limited. 2012. P. 1061.
3. Тарараева Е.М., Муравьева Л.С. Влияние кислорода и олова на механические свойства сплавов циркония с 1 и 2,5 % Nb. *Строение и свойства сплавов для атомной энергетики.* / под ред. О.С. Иванова, Т.А. Бабаева. М.: Наука, 1973. С. 158–172.
4. Войтович Р.Ф. Окисление циркония и его сплавов. Киев: «Наукова думка», 1989, 288 с.
5. Физическое материаловедение: Учебник для вузов: в 6 т./ под общей ред. Б.А. Калина. Т. 6. Часть 1. Конструкционные материалы ядерной техники/ ред. Б.А. Калинин, П.А. Платонов, И.И. Чернов, Я.И. Штромбах. М.: МИФИ, 2008. 672 с.
6. Вахрушева В.С., Коленкова О.А., Сухомлин Г.Д. Влияние содержания кислорода на пластичность, повреждаемость и параметры акустической эмиссии металла труб из сплава Zr-1%Nb. *Вопросы атомной науки и техники. Серия: Физика радиационных повреждений и радиационное материаловедение* (88). 2005. №5. С. 104–109.
7. Черняева Т.П., Стукалов А.И., Грицина В.М. Влияние кислорода на механические свойства циркония. *Вопросы атомной науки и техники. Серия: Вакуум, чистые материалы, сверхпроводники* (12). 2002. №1. С. 96–102.
8. Чернов И.И., Калинин Б.А., Бинюкова С.Ю., Стальцов М.С. Влияние легирования и термической обработки на структуру и свойства циркония. Учебное пособие. М.: МИФИ, 2007. 84 с.
9. Martin Steinbrilck, Mirco Gross. Deviations from parabolic kinetics during oxidation of zirconium alloys. *Zirconium in the Nuclear industry*, 17th International Symposium on Zirconium in the Nuclear Industry on February 3–7, 2013 in Hyderabad, India, P. 979–1001. DOI: 10.1520/STP154320130022.
10. Selmi Nouredine, Sari Ali. Study of Oxidation Kinetics in Air of Zircaloy-4 by in Situ X-Ray Diffraction. *Advances in Materials Physics and Chemistry*. 2013. Vol.3 No.2. С. 168–173. DOI: 10.4236/ampc.2013.32023.
11. Griboaud L., Arias D., Abriata J. The N-Zr (Nitrogen-Zirconium) system. *Journal of Phase Equilibria*. 1994. Vol. 15, No. 4. P. 441–449.
12. Nikulin S.A., Rozhnov A.B., Gusev A.Yu. et al. Fracture resistance of Zr-Nb alloys under low-cycle fatigue tests. *Journal of Nuclear Materials*. 2014. Vol. 446, Is.1–3. P. 10–14. DOI: <https://doi.org/10.1016/j.jnucmat.2013.11.039>.

13. Lee D., Hill P.T. Effect of oxygen on the fatigue behavior of Zircaloy. *Journal of Nuclear Materials*. 1976. Vol. 60. P. 227–230.
14. Ажажа В.М., Борц Б.В., Бутенко І.М. та ін. Виробництво партії трубних заготовок трекс-труб та виготовлення дослідно-промислової партії твельних труб зі сплаву Zr-1Nb із вітчизняної сировини. *Наука та інновації*. 2006. Т. 2, №6. С. 18–30. DOI: 10.15407/scin2.06.018.
15. Birchley Jonathan & Leticia Fernandez-Moguel. Simulation of air oxidation during a reactor accident sequence: Part 1 – Phenomenology and model development. *Annals of Nuclear Energy*. 2012. 40. 163–170. DOI: <https://doi.org/10.1016/j.anucene.2011.10.019>.

References

1. Lemaignan, C., & Motta, A.T. (2006). Zirconium Alloys in Nuclear Applications. *Materials Science and Technology*, 2–51. DOI: <https://doi.org/10.1002/9783527603978.mst0111>.
2. Damien, Feron (Eds.). (2012). *Nuclear corrosion science and engineering*. Woodhead Publishing Limited. P. 1061.
3. Tararaeva, E.M., & Murav'eva, L.S. (1973). Effect of oxygen and tin on the mechanical properties of zirconium alloys with 1 and 2.5 % Nb. *Structure and properties of alloys for nuclear power engineering*. Moscow: Nauka.
4. Voitovich, R.F. (1989). *Oxidation of zirconium and its alloys*. Kiev: Science dumka.
5. Kalin, B.A., Platonov, P.A., Chernov, I.I., & Strombakh, Ya.I. (2008). *Physical Material Science. 6. Part 1. Structural materials of nuclear engineering*. Moscow: MIFI.
6. Vakhrusheva, V.S., Kolenkova, O.A., & Sukhomlin, G.D. (2005). Effect oxygen content on plasticity, damage and acoustic emission parameters of Zr-1%Nb tubes. *Problems of Atomic Science and Technology*. 5(88). 104–109.
7. Chernyaeva, T.P., Stukalov, A.I., & Gritsina, V.M. (2002). Effect of oxygen on the mechanical properties of zirconium. *Problems of Atomic Science and Technology*. 1(12). 96–102.
8. Chernov, I.I., Kalin, B.A., Binyukova, S.Yu., & Staltsov M.S., (2007). *Effect of alloying and heat treatment on the structure and properties of zirconium: a textbook*. Moscow: MEPhI.
9. Steinbrilck, M., & Gross, V. (2014). Deviations from parabolic kinetics during oxidation of zirconium alloys. Zirconium in the Nuclear industry: 17th International Symposium on Zirconium in the Nuclear Industry on February 3–7, Hyderabad, India. P. 979-1001. DOI: 10.1520/STP154320130022.
10. Selmi Nouredine, Sari Ali. (2013). Study of Oxidation Kinetics in Air of Zircaloy-4 by in Situ X-Ray Diffraction. *Advances in Materials Physics and Chemistry*, 3, 2, 168–173. DOI: 10.4236/amc.2013.32023.
11. Gribaudo, L., Arias, D., & Abriata, J. (1994). The N-Zr (Nitrogen-Zirconium) system. *Journal of Phase Equilibria*, 4(15), 441–449.
12. Nikulin, S.A., Rozhnov, A.B., & Gusev, A.Yu., et al. (2004). Fracture resistance of Zr-Nb alloys under low-cycle fatigue tests. *Journal of Nuclear Materials*, 446, 1–3, 10–14. DOI: <https://doi.org/10.1016/j.jnucmat.2013.11.039>.
13. Lee, D., & Hill, P.T. (1976). Effect of oxygen on the fatigue behavior of Zircaloy. *Journal of Nuclear Materials*, 60, 227–230.
14. Azhazha, B.M., Borts, B.V., & Butenko, I.M. et al. (2006). Production of the party of round billets for trex-pipes and making of the experimental industrial party of pipes from Zr1Nb alloy from domestic raw materials. *Science and Technology*, 2(6), 18–30. DOI: 10.15407/scin2.06.018.
15. Birchley, J., & Leticia, F-M. (2012). Simulation of air oxidation during a reactor accident sequence: Part 1 – Phenomenology and model development. *Annals of Nuclear Energy*, 40, 163–170. DOI: 10.1016/j.anucene.2011.10.019.

Воєводін Віктор Миколайович; Voyevodin Victor, ORCID: <https://orcid.org/0000-0003-2290-5313>

Труш Василь Степанов; Trush Vasyl, ORCID: <http://orcid.org/0000-0002-2264-3918>

Лук'яненко Олександр Геннадійович; Luk'yanenko Alexander, ORCID: <http://orcid.org/0000-0001-6642-2300>

Федірко Віктор Миколайович; Fedirko Viktor, ORCID: <https://orcid.org/0000-0002-4337-1691>

Стоєв Петро Ільїч; Stoev Petro, ORCID: <https://orcid.org/0000-0001-7942-5850>

Тихоновський Михайло Андрійович; Tikhonovsky Mikhail, ORCID: <https://orcid.org/0000-0001-5889-0366>

Received August 01, 2018

Accepted August 10, 2018